



Instruction Manuals of the Signal Converter VM-5011B (Detailed Edition)

Issued by **IMV CORPORATION**
Document No. TVE-6-4280E
Revision Ver1.00

Index

Introduction	2
Safety Precautions.....	2
1. Overview.....	4
2. Features.....	4
3. System Composition	5
3.1 System Block Diagram	5
3.2 Equipment Configuration	5
4. Installation	6
4.1 Installation of the Accelerometer	6
4.2 Installation of the Cable	7
4.3 Installation of the Converter	7
5. Wiring.....	7
6. Power on the Converter.....	11
7. Change of Measurement Range and DC Output.....	11
8. How to Connect with the VP-8021A.....	13
9. Handling Precautions.....	14
10. Warranty	14
11. Specifications	15
11.1 Specifications of the Converter (VM-5011B)	15
11.2 Standard Characteristic of the Converter.....	16
11.3 Outer Dimensions of the Converter	16
11.4 Specifications of the Accelerometer.....	17
12. Maintenance and Troubleshooting.....	22
12.1 Maintenance	22
12.2 Troubleshooting	22
Appendix.....	23
Appendix 1 In case of the accelerometer is not grounded	23
Appendix 2 About voltage input connection specifications	24
Appendix 3 About the Magnet for mounting the Accelerometer.....	26
VM-5011 Series Lineup	27

Introduction

Thank you for purchasing Signal Converter "VM-5011 Series".

Read this manual carefully to ensure the best performance and longest product life of the device. In addition, pay attention to the cautions described below to use the product safely.

◆ Notes



- (1) The Signal Converter (hereinafter referred to as "converter") is a device that diagnoses various vibrations for industrial equipment such as electric motors and pumps, and consumer equipment. Do not use it for any other purpose.
- (2) When wiring the converter and piezoelectric acceleration sensor (hereinafter referred to as "accelerometer"), make sure that power supply source is "OFF" before performing the work.
- (3) Ground the system separately from the power equipment, and make sure to use the terminal block or binding post.
- (4) Signal line from the accelerometer and output signal line from the converter should not be bundled with the power line or the signal line that generates noise but should be installed in a separate system.

Safety Precautions

It describes the items that you should follow to prevent harm to customers and other people and damage to property, and to use this product safely. Please be sure to read this manual and attached documents before use, and fully understand the contents for use.

After reading this manual, be sure to place it in a location so that you can always refer to it.

Expressions of Safety Instructions

Indication	Meaning of Indication
 Warning	Indicates the contents that may cause a dangerous situation of death or serious injury if mishandled.
 Caution	Indicates the contents that may cause serious injury or property damage if mishandled.
Note	Describes cases where there is no risk of injury to the operator, but it is expected to cause damage or failure to this product or other equipment or devices.

* "Serious injuries" are those with residual aftereffects such as blindness, injury, burns, electric shock, fractures, poisoning, and those requiring hospitalization or long-term hospital visits for treatment.

* "Minor injuries" are those that do not require hospitalization or long-term hospital visits for treatment (other than the "serious injuries" above).

In addition to the danger level classification, this document also uses the following notation:

Memo: "Memo" describes supplementary explanations that could not be explained in the text and information that is useful to know.

◆ For Safe Use

 **Warning**

- (1) Do not use this product as a life-threatening alarm device.
- (2) When installing this product or peripheral devices in a high place, be sure to use a workbench such as a stepladder.
- (3) Do not use it in abnormal conditions such as smoke, strange odor, or abnormal noise. Also, do not disassemble or modify this product regardless of whether it is normal or abnormal. It may cause electric shock, fire, or malfunction.
- (4) When the accelerometer is installed near a moving part of the machine, make sure that it is stopped before installing the accelerometer. Do not perform any installation work while the machine is in operation.

 **Caution**

- (1) Be sure to wear a helmet when working at heights.
- (2) When installing this product or peripheral devices in a high place, fix them firmly. If this product or peripheral devices fall, an accident may occur.
- (3) When the converter is energized, do not touch the terminal block carelessly.

Note

- (1) When connecting the accelerometer to the converter, check the method that matches the specifications of the device to be connected. Improper connection may cause the product or connected devices to malfunction or be damaged.
- (2) Use this product in the environment described in this manual. If you use it in an environment not described in this manual, unexpected problems may occur. In addition, if the main unit is damaged or peripheral devices are damaged due to the above reasons, the warranty will be void.
- (3) Do not attach the accelerometer to the interference point or operating point of the machine to be measured. The machine may damage.

Memo

- (1) The converter and the accelerometer are precision devices. Please handle it with care.
- (2) When performing automatic measurement operation using this product, it may not be possible to record measurement data as expected if the settings are not correct. Please check in the actual environment whether the measurement data can be obtained as expected, and after confirming that there are no problems, start operation in earnest.

1. Overview

The purpose of this product is to constantly monitor vibrations for safety confirmation during operation of various rotating devices such as electric motors and pumps, detection of abnormal operations, detection of deterioration phenomena, and early maintenance.

Vibration of the electric motors or pumps is detected by the accelerometer, vibration signal is converted by the converter as the acceleration and the velocity. These vibration level output as DC current of 4-20mA or DC voltage of 0-10V.

In addition, the vibration signal output AC voltage of 0-1Vrms and can be used for analysis of vibration waveforms.

2. Features

- (1) Simultaneous monitoring of the acceleration and the velocity levels.
- (2) Several accelerometers are available for connecting to the converter.
- (3) The converter is compact and can be mounted on DIN rail.

3. System Composition

3.1 System Block Diagram

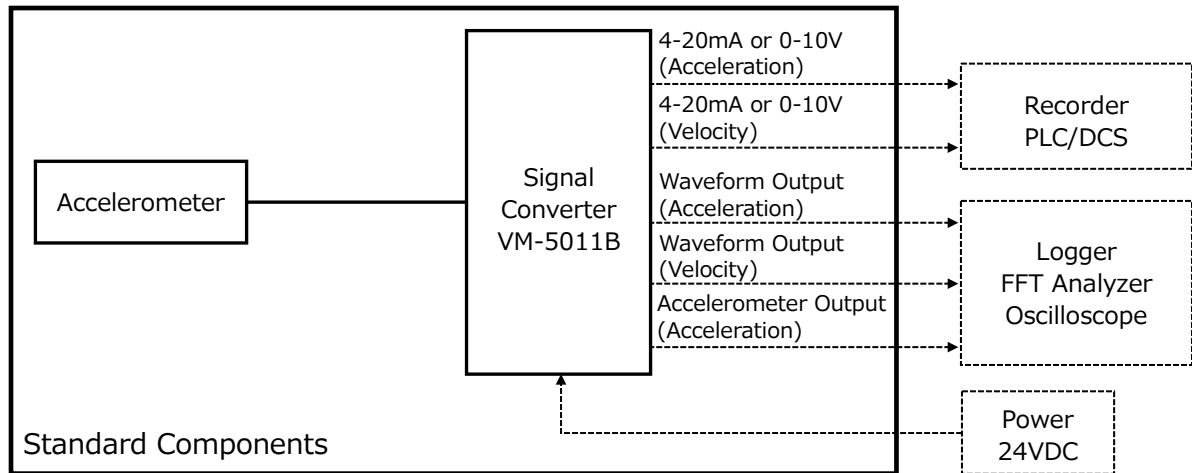

3.2 Equipment Configuration

● Main Components

Name	Model	Qty	Remarks
Signal Converter (Converter)	VM-5011B	1	
Accelerometer	VP-1001000206 (VP-100)	1	Cable Direct Leading
* Select one of the models at the time of purchase	VP-1001000106 (VP-100R)		Cable Direct Leading (Waterproof Type)
	VP-1001005406		Cable with Connector (Not included in price)
	VP-8021A		Cable with Connector (Standard Accessory)

Memo

- (1) The above quantity is for one set.
- (2) Refer to the options below for the cable of the VP-1001005406.
- (3) Standard cable length of the accelerometer is 5m.
- (4) Detailed specifications of the accelerometer refer to "section 11.4".

● Option (Not included in price)

Name	Model	Qty	Remarks
Cable of the VP-1001005406 Length: 5m	MS-AC010-5		Straight Connector
	MS-AC011-5		Right Angle Connector
Magnet for mounting Accelerometer	MH-205R		for Flat Surface
	MH-206R		for Curved Surface

4. Installation

4.1 Installation of the Accelerometer

Memo

The installation method of the accelerometer in this section applies to the VP-100 series. For instructions on how to install the VP-8021A, please refer to the VP-8021A instruction manual.

The accelerometer detects vibration on the bottom. Therefore, it is an important condition for detecting vibration that the bottom surface is in close contact with the vibrating part.

Ideally, the surface of the equipment on which the accelerometer will be installed should be as flat as possible, and the contact surface should be coated with silicone grease or oil (Fig. 4-1).

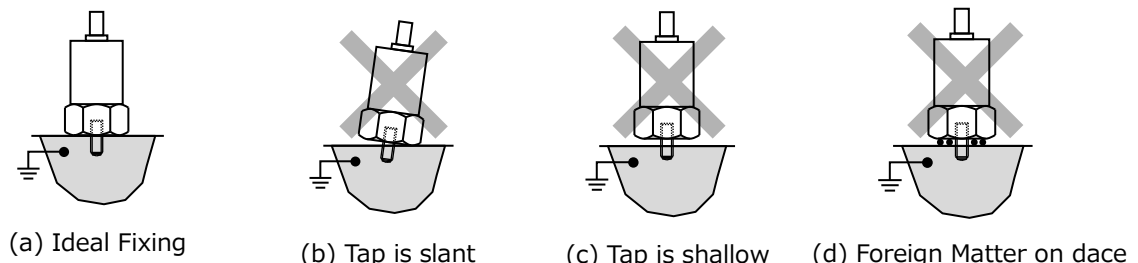

Fig.4-1 Installation of the Accelerometer

Note

Be sure to check the following items before installing the accelerometer.

- (1) Is the instrument to be measured grounded

If the accelerometer mounting surface (measurement target instrument) is not properly grounded, it may become charged and may fail.

- (2) Is the accelerometer mounting surface cleanly finished

Remove completely dirt, dust, and paint at the mounting surface. Also, make sure that the tapped holes are upright with no foreign matter on the threads.

Processing of the accelerometer mounting surface

The degree of close contact between the accelerometer and mounting surface directly affects the characteristics of the accelerometer.

Especially, since the accelerometer measures up to high frequencies, make mounting surface flat and tap M6 female screw perpendicular to mounting surface (Fig.4-2).

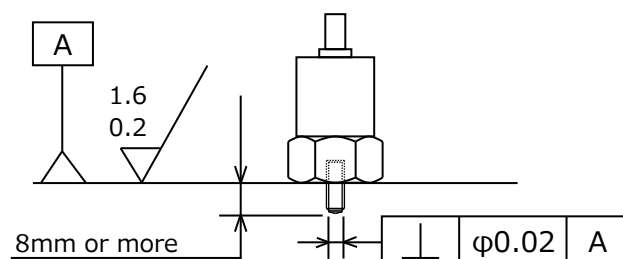

Fig.4-2 Processing of the accelerometer mounting surface

4.2 Installation of the Cable

- (1) The accelerometer cable fix away from the device to be measured and at the location closest to it, and then fix the cable appropriately so that there is no slack.
- (2) When relaying the accelerometer cable, use the junction box, and use the twisted pair shielded cable that takes the installation environment into consideration. Also, keep the wiring as short as possible.

Memo

- (1) If the accelerometer cable is parallel to the power line such as the inverter, noise from the power line may affect the measurement. Install the accelerometer cable as far away from the power line as possible.
- (2) To protect the accelerometer cable from vibration, use a flexible conduit up to its near of installation point.
- (3) When relaying the accelerometer cable using the junction box, install it in an environment with as little noise as possible (in a place where noise countermeasures have been taken).

4.3 Installation of the Converter

The converter is mounted using 35mm DIN rail (Fig.4-3).

- (1) Hook the upper side of the converter body on DIN rail.
- (2) While pulling down the stopper on the lower side of the converter, hook it on the DIN rail.

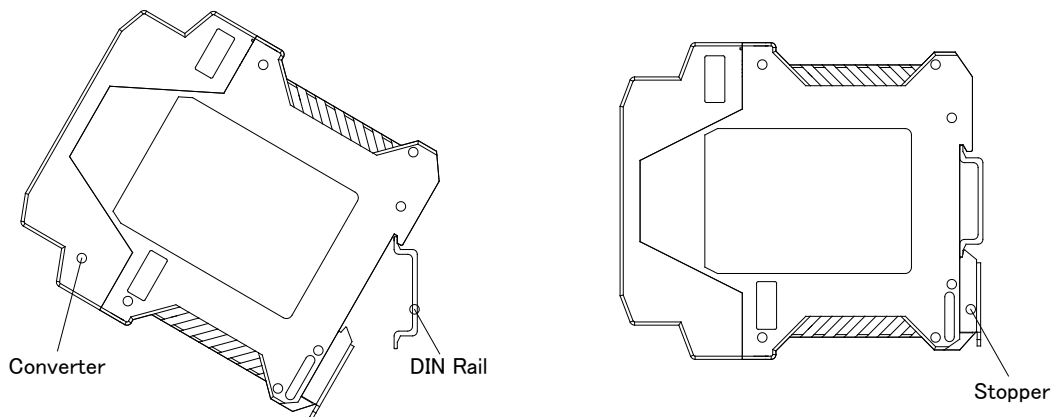

Fig.4-3 Installation of the Converter

Memo

Install the converter in a clean place with as little noise as possible and little vibration or temperature change.

5. Wiring

Connect the power supply, the accelerometer and various subsequent instruments according to the wiring diagram shown from p8 to p10.

V0827-9-4280A

VP-1001000206 (VP-100)
VP-1001000106 (VP-100R)
Wiring Diagram

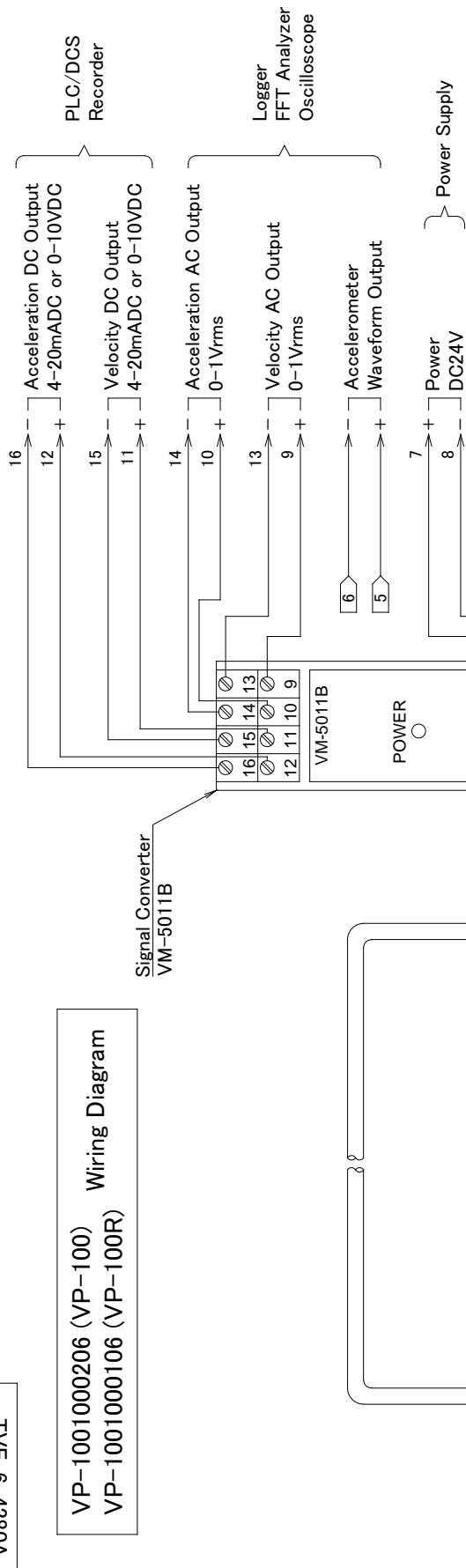

VM-5011B Use of each Terminal

Number	How to Use
1	Accelerometer Input + (SIG)
2	Accelerometer Input - (COM)
3	Accelerometer Input Shield Wire
4	Not Normally Use (FG)
5	Accelerometer Waveform Output +
6	Accelerometer Waveform Output -
7	Power 24VDC +
8	Power 24VDC -
9	Velocity AC Output +
10	Acceleration AC Output +
11	Velocity DC Output +
12	Acceleration DC Output +
13	Velocity AC Output -
14	Acceleration AC Output -
15	Velocity DC Output -
16	Acceleration DC Output -

Not Normally Use
(See Note (2))

POWER Lamp Condition

- OFF: Power is not supplied.
Accelerometer cable is broken.
- O N: Normal (Measurement Status)

Note

- (1) Make sure that the instrument to which the accelerometer is to be attached (measurement target instrument) is grounded.
- (2) If the instrument to which the accelerometer is attached is not grounded, or if the accelerometer is attached insulated from it, ground terminal No.4 of the converter.

名称 VM-5011B Wiring Diagram
Drawing Name

图番 TVE-6-4280A
Drawing No.

IMV CORPORATION

B0827-9-4280B

VP-1001005406 Wiring Diagram

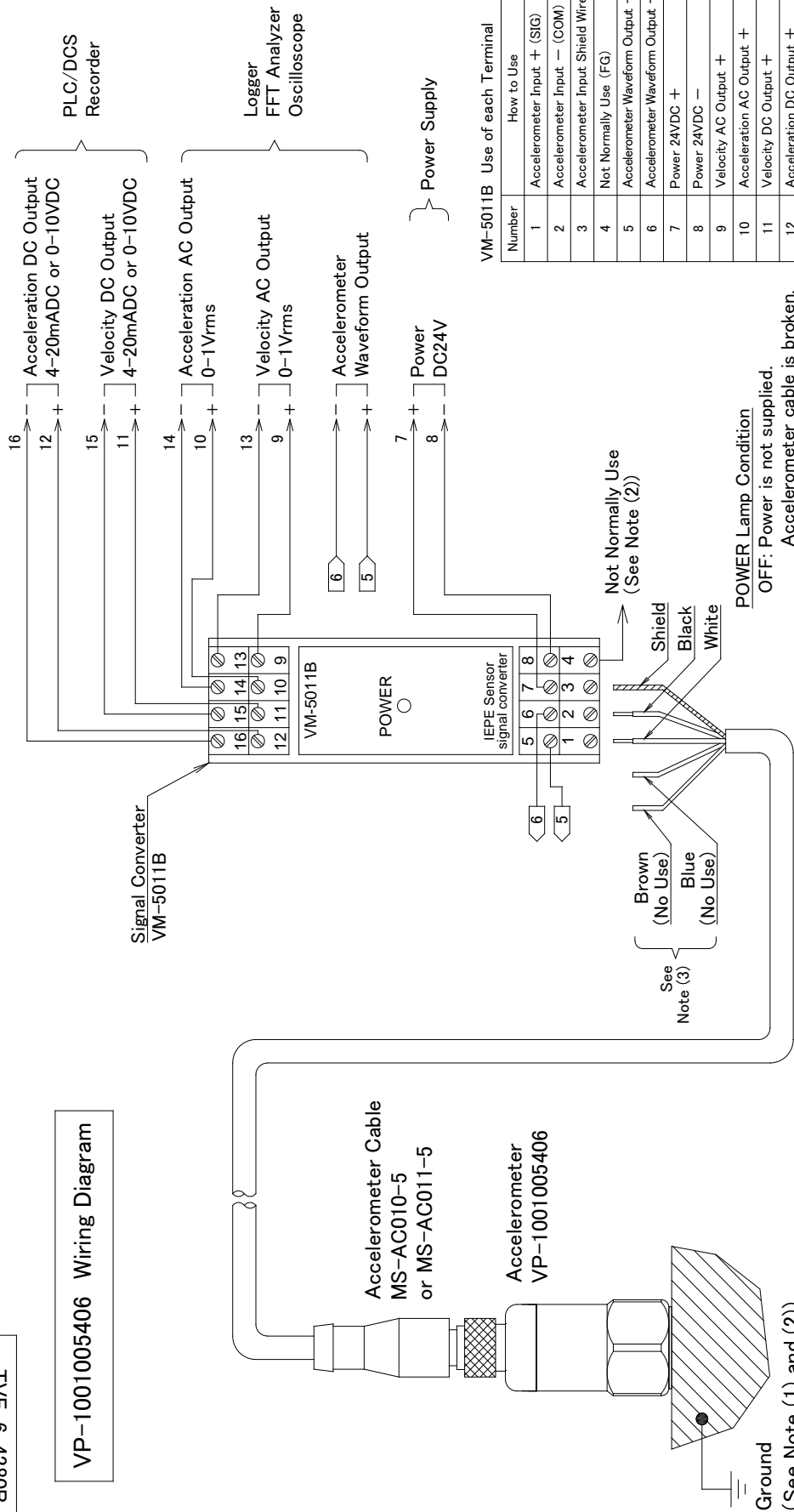

VM-5011B Use of each Terminal

Number	How to Use
1	Accelerometer Input + (SIG)
2	Accelerometer Input - (COM)
3	Accelerometer Input Shield Wire
4	Not Normally Use (FG)
5	Accelerometer Waveform Output +
6	Accelerometer Waveform Output -
7	Power 24VDC +
8	Power 24VDC -
9	Velocity AC Output +
10	Acceleration AC Output +
11	Velocity DC Output +
12	Acceleration DC Output +
13	Velocity AC Output -
14	Acceleration AC Output -
15	Velocity DC Output -
16	Acceleration DC Output -

Not Normally Use
(See Note (2))

Shield
Black
White

POWER Lamp Condition

- OFF: Power is not supplied.
Accelerometer cable is broken.
- O N: Normal (Measurement Status)

Note

- (1) Make sure that the instrument to which the accelerometer is to be attached (measurement target instrument) is grounded.
- (2) If the instrument to which the accelerometer is attached is not grounded, or if the accelerometer is attached insulated from it, ground terminal No.4 of the converter.
- (3) Unused wires (brown and blue) shall be insulated.

名称 Drawing Name	VM-5011B Wiring Diagram
図番 Drawing No.	TVE-6-4280B

IMV CORPORATION

00827-9-4280C

VP-8021A Wiring Diagram

Signal Converter (See Note (4))
VM-5011B

Note

- (1) Make sure that the instrument to which the accelerometer is to be attached (measurement target instrument) is grounded.
- (2) If the instrument to which the accelerometer is attached is not grounded, or if the accelerometer is attached insulated from it, ground terminal No.4 of the converter.
- (3) For details on the handling of the VP-8021A, please refer to the instruction manual for the VP-8021A.
- (4) In case of connecting the VP-8021A, it is necessary to change the jumper socket setting inside the VM-5011B. Refer to "8. Case of using the VP-8021A" for how to change.

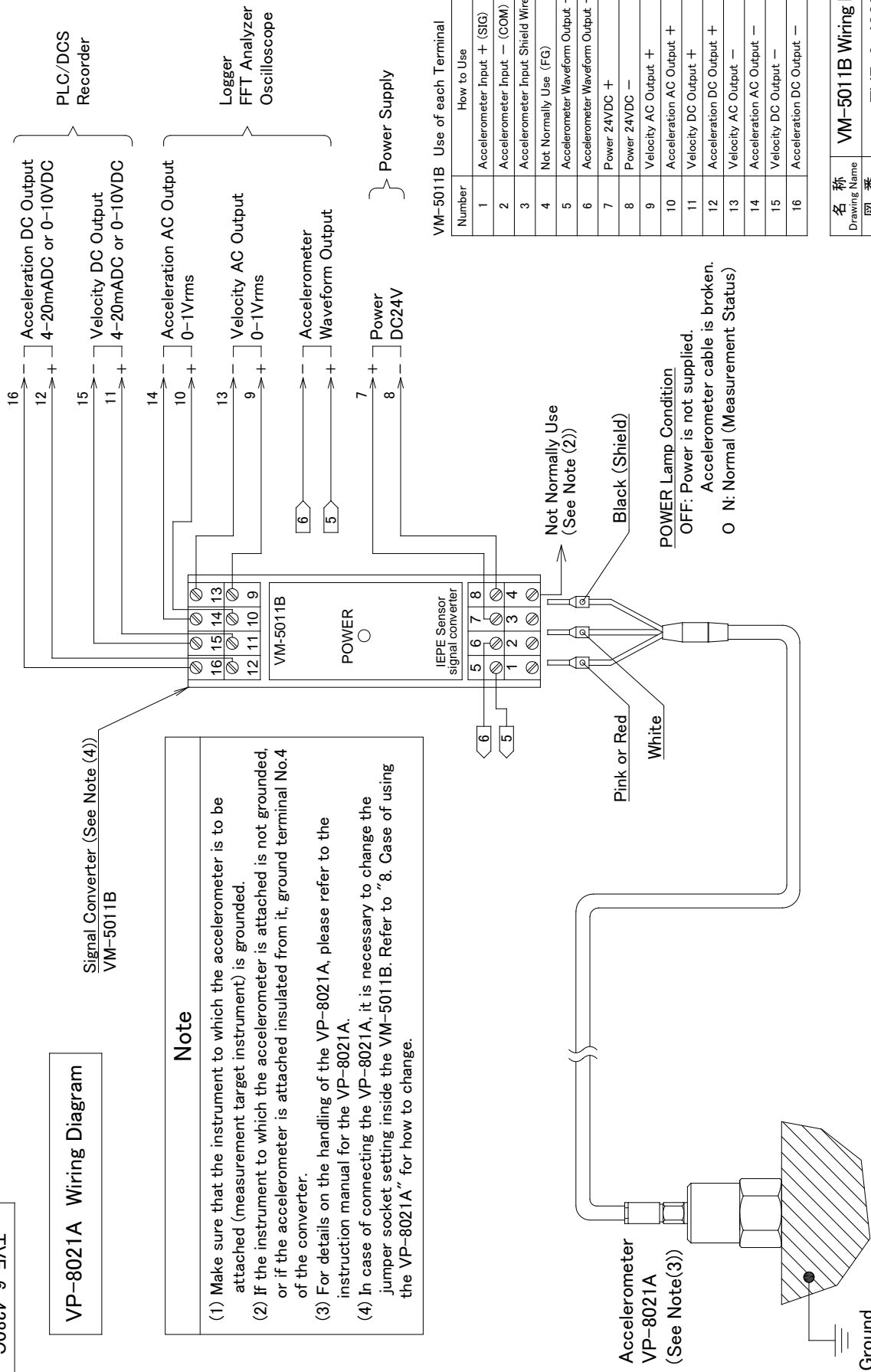

VM-5011B Use of each Terminal

Number	How to Use
1	Accelerometer Input + (SIG)
2	Accelerometer Input - (COM)
3	Accelerometer Input Shield Wire
4	Not Normally Use (FG)
5	Accelerometer Waveform Output +
6	Accelerometer Waveform Output -
7	Power 24VDC +
8	Power 24VDC -
9	Velocity AC Output +
10	Acceleration AC Output +
11	Velocity DC Output +
12	Acceleration DC Output +
13	Velocity AC Output -
14	Acceleration AC Output -
15	Velocity DC Output -
16	Acceleration DC Output -

POWER Lamp Condition
 OFF: Power is not supplied.
 Accelerometer cable is broken.
 O N: Normal (Measurement Status)

名称 Drawing Name	VM-5011B Wiring Diagram
図番 Drawing No.	TVE-6-4280C
IMV CORPORATION	

6. Power on the Converter

After connecting according to section 5, turn on the power and the "POWER" lamp on the front of it will light up (Fig.6-1).

Memo

- (1) The converter takes about 30 seconds from power-on to stability.
- (2) If "POWER" lamp is off even though power is being supplied, the accelerometer cable may not be connected properly, or the accelerometer cable may be broken. In such a case, turn off power supply to the converter once, check that the accelerometer cable is connected correctly, and then turn on power again.

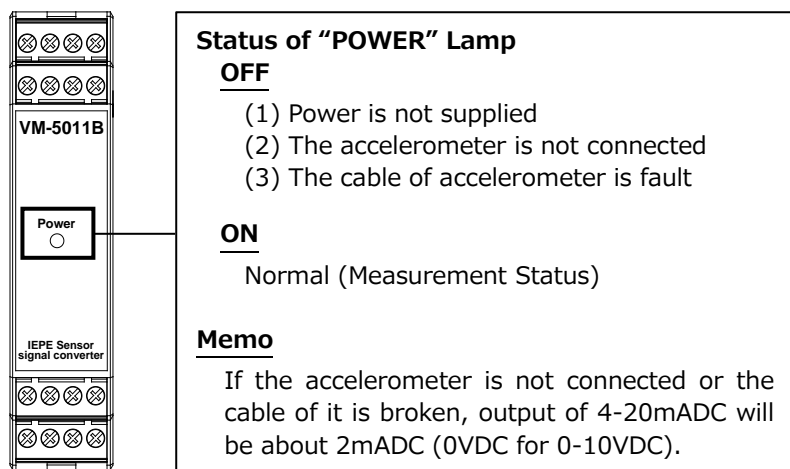

Fig.6-1 POWER Lamp Indication

7. Change of Measurement Range and DC Output

The converter can change measurement range and DC output. Follow the procedure below.

Setting Method

- (1) Turn off power supply to the converter and disconnect all wiring connected to it.
- (2) Remove the converter from DIN rail.
- (3) Push lock hooks on the top and bottom of the converter with a flat-blade screwdriver. Release the lock, then hold upper housing and pull it out from base housing (see Fig.7-1).

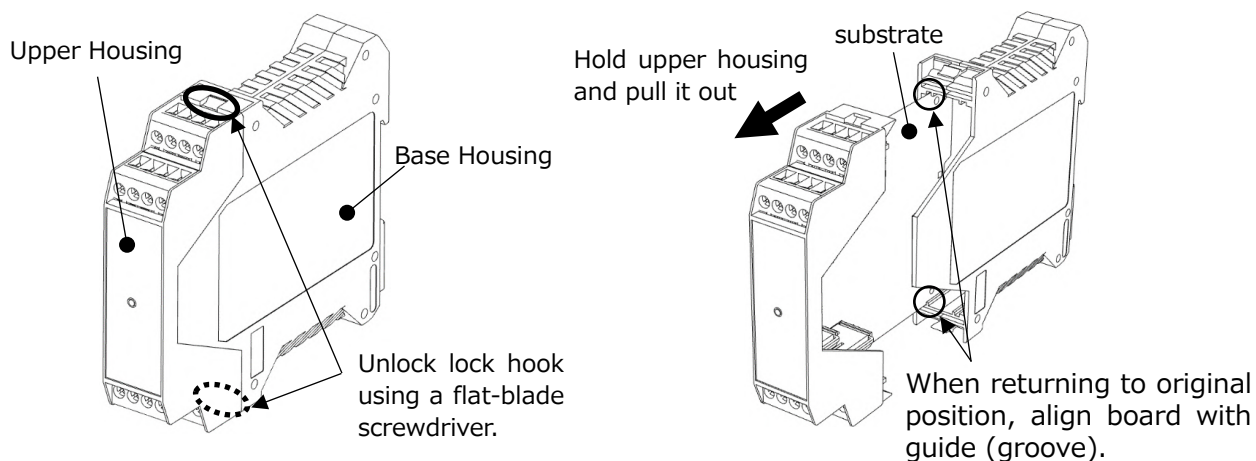
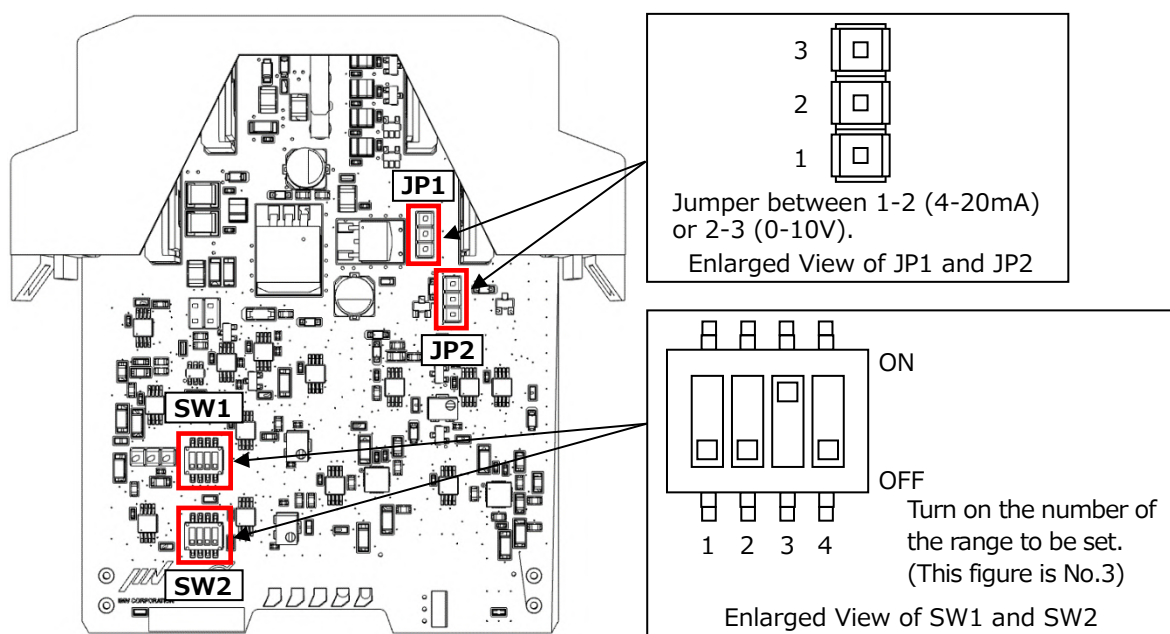

Fig.7-1 Pulling out upper housing

(4) Change measurement range and DC output according to Fig.7-2 below.



"JP" and "SW" Setting Item			Setting	Factory Default
JP1	Acceleration DC Output	1-2	4-20mADC	✓
		2-3	0-10VDC	
JP2	Velocity DC Output	1-2	4-20mADC	✓
		2-3	0-10VDC	
SW1 (*)	Acceleration Measuring Range	1	0~10m/s ² rms	
		2	0~25m/s ² rms	
		3	0~50m/s ² rms	✓
		4	0~100m/s ² rms	
SW2 (*)	Velocity Measuring Range	1	10mm/s rms	
		2	25mm/s rms	
		3	50mm/s rms	✓
		4	100mm/s rms	

(*) Do not turn on more than one switch.

Fig.7-2 Setting of Measurement Range and DC Output

- (5) After completing the settings, insert upper housing into base housing, check that lock hook is locked, attach it to DIN rail, and reconnect each cable.

Note

- (1) **Do not change or adjust jumpers or volumes other than those specified in this manual.** Correct measurement may not be possible.
- (2) The converter is a precision device. Please handle it with care.
- (3) Please do not forget to record and manage the settings.

8. How to Connect with the VP-8021A

The converter also supports connection with our MEMS high-frequency vibration sensor VP-8021A.

The setting of factory default connecting accelerometer is the VP-100 (*). When connecting the VP-8021A to the converter, it is necessary to change jumper JP4 settings on circuit board (see Fig.8-1).

(*) VP-1001000206 (VP-100), VP-1001000106 (VP-100R), and VP-1001005406 are applicable.

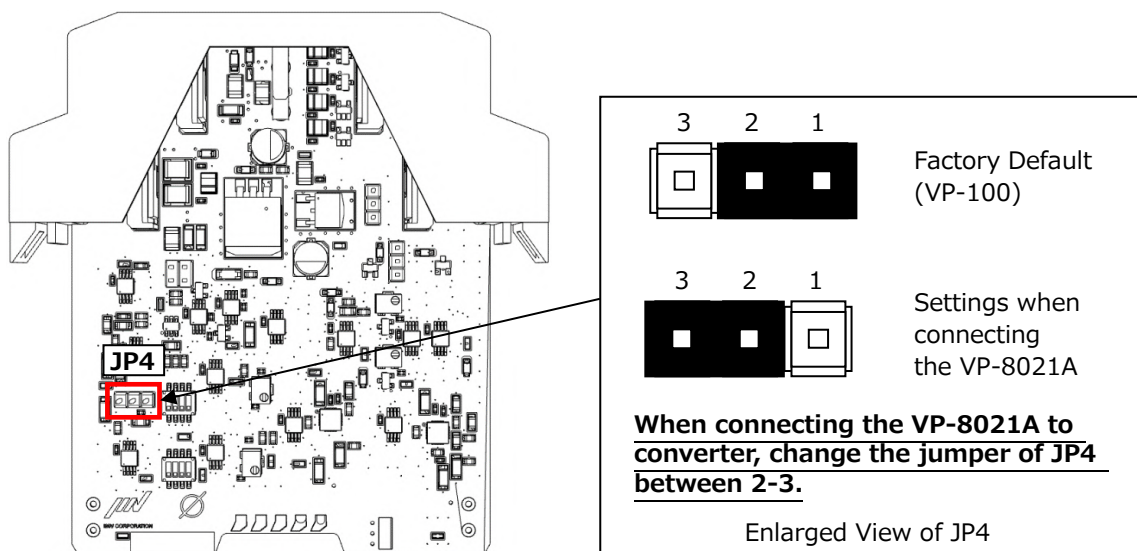

Fig.8-1 Jumper change when connecting the VP-8021A

Refer to "Section 5" for how to connect the VP-8021A to the converter.

Memo

- (1) Refer to "Section 7" for how to pull out the board.
- (2) For more information on the VP-8021A, please check our website.

URL: <https://we-are-imv.com/en/>

9. Handling Precautions

Caution

- (1) Avoid moving the accelerometer during vibration measurement. When moving, turn off the power supply to the converter before moving.
- (2) Use a 24VDC for this product and use a stable power supply with little external noise (noise surge pulse).

Note

When storing this product for a long period of time, avoid places exposed to direct sunlight, high humidity, and dusty places, and store it in a place within the operating temperature and humidity range.

Memo

When disposing of this product, dispose of it as industrial waste.

10. Warranty

This product is shipped after strict inspection in our factory. But in case the system has a fault caused by the responsibility of IMV as the defect under production and material during the warranty period, we will repair or replace it free of charge. However, consumables such as lamps will be excluded.

The warranty period for this product is one year from the date of shipment. However, even within the warranty period, repairs will be charged in the following cases.

- (1) Any damage and breakdown caused by natural disasters such as fire, earthquake, flood, lightning damage.
- (2) Any transporting, moving, or dropping which does not relate to us after finishing our delivery.
- (3) Any error operation, unusual power supply input, and the fault caused by disassembling/repairing/modifying by customer.

11. Specifications

11.1 Specifications of the Converter (VM-5011B)

Model	VM-5011B	
Input Range	0 to 500m/s ²	
Measuring Range of Frequency	Acceleration	10Hz to 10kHz (*2)
	Velocity	10Hz to 1kHz (*2) (ISO 2954:2012 Filter Characteristics compliant)
Measuring Range (*1)	Acceleration	<input type="checkbox"/> 10m/s ² rms <input type="checkbox"/> 25m/s ² rms <input checked="" type="checkbox"/> 50m/s ² rms <input type="checkbox"/> 100m/s ² rms
	Velocity	<input type="checkbox"/> 10mm/s rms <input type="checkbox"/> 25mm/s rms <input checked="" type="checkbox"/> 50mm/s rms <input type="checkbox"/> 100mm/s rms
Connect Accelerometer (*1)	<input checked="" type="checkbox"/> VP-100 (*3) <input type="checkbox"/> VP-8021A	
DC Output (*1)	Acceleration	<input checked="" type="checkbox"/> 4-20mA (Load 500Ω or lower) <input type="checkbox"/> 0-10V (Load 100kΩ or higher)
	Velocity	<input checked="" type="checkbox"/> 4-20mA (Load 500Ω or lower) <input type="checkbox"/> 0-10V (Load 100kΩ or higher)
	Response Speed	τ=0.3s 63% Response
AC Output	Acceleration	0-1Vrms (Load 100kΩ or higher)
	Velocity	0-1Vrms (Load 100kΩ or higher)
Linearity	DC Output	within ±3%F.S
	AC Output	within ±5%
Accelerometer Waveform Output	Depends on Voltage Sensitivity of the Accelerometer Bias Voltage: 9VDC	
Operating Temperature and Humidity Range	0 to 50°C, 95%RH or less without freezing or condensation	
Suitable Cable of Terminal Block	0.2 to 2.5mm ² (Single wire / Stranded wire) (AWG12 to 24)	
Power Supply of the Converter	24VDC ±10%	
Power Supply of Accelerometer	24VDC 3.5mA±20%	
Power Consumption	3W or less	
Case Material	Resin	
Outer Dimensions (Excluding protrusions)	W22.6×H99×D113.6mm (See p16)	
Weight	Approx. 150g	

*1 "■" is factory default settings.

*2 Refer to "11.2 Standard Characteristic of the Converter".

*3 VP-1001000206 (VP-100), VP-1001000106 (VP-100R), and VP-1001005406 are applicable.

11.2 Standard Characteristic of the Converter

Acceleration

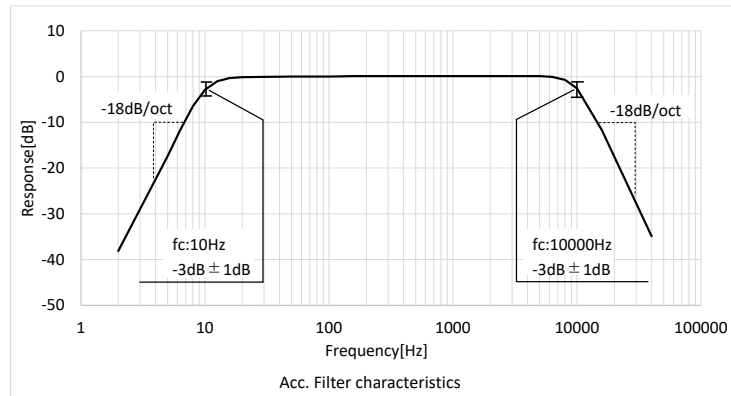

Velocity

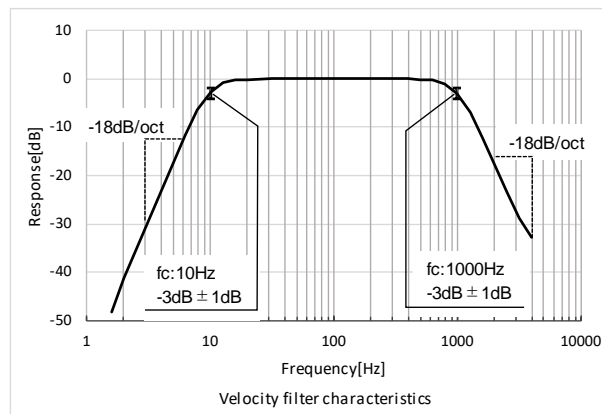

11.3 Outer Dimensions of the Converter

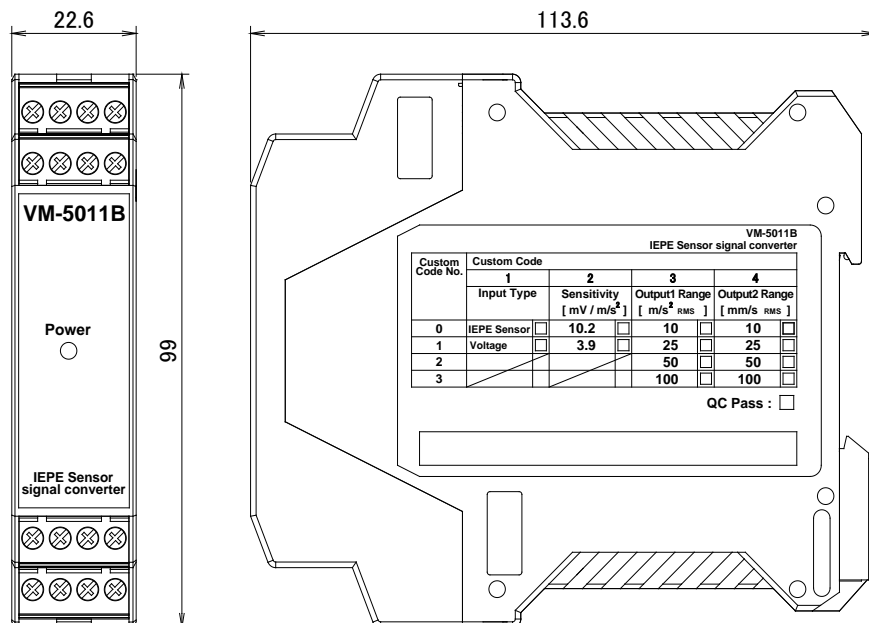

Unit [mm]

11.4 Specifications of the Accelerometer

(1) VP-1001000206 (VP-100) (Cable Direct Leading Type)

Detecting Method	Compression Type
Resonance Frequency	22kHz or more
Frequency Range	2Hz to 10kHz ± 1 dB
Voltage Sensitivity	10.2mV/(m/s ²) $\pm 10\%$
Max Measurement Acceleration	784m/s ²
Drive Current	0.5 to 8mA (18 to 30VDC)
Operating Temperature	-55 to +140°C
Protection Class	IP65
Weight	Approx. 106g (without Cable)
Case Material	SUS303
Mounting Method	M6 Screw
Cable Sheath Material	SUS Braided Cable
Cable Length	5m (Standard Length)
Outer Dimensions	See below Figure

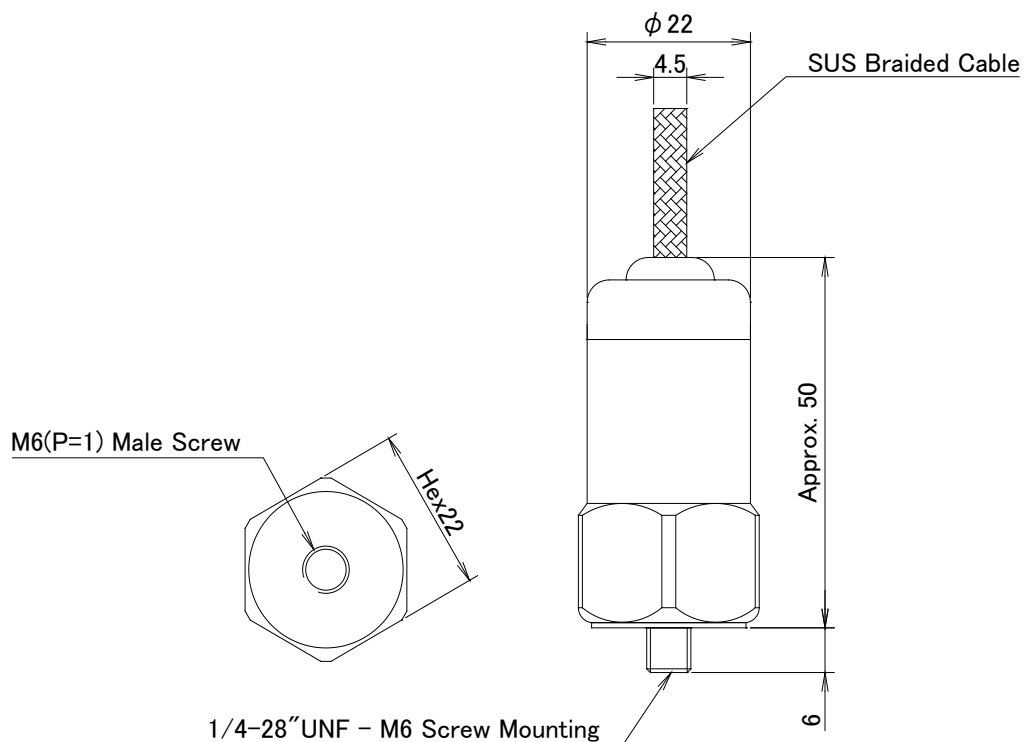

Outer Dimensions of the VP-1001000206 (Unit: mm)

(2) VP-1001000106 (VP-100R) (Waterproof Type with Oil-resistant Cable)

Detecting Method	Compression Type
Resonance Frequency	22kHz or more
Frequency Range	2Hz to 10kHz ± 1 dB
Voltage Sensitivity	10.2mV/(m/s ²) $\pm 10\%$
Max Measurement Acceleration	784m/s ²
Drive Current	0.5 to 8mA (18 to 30VDC)
Operating Temperature	-55 to +140°C
Protection Class	IP65
Weight	Approx. 125g (without Cable)
Case Material	SUS303
Mounting Method	M6 Screw
Cable Sheath Material	PUR
Cable Length	5m (Standard Length)
Outer Dimensions	See below Figure

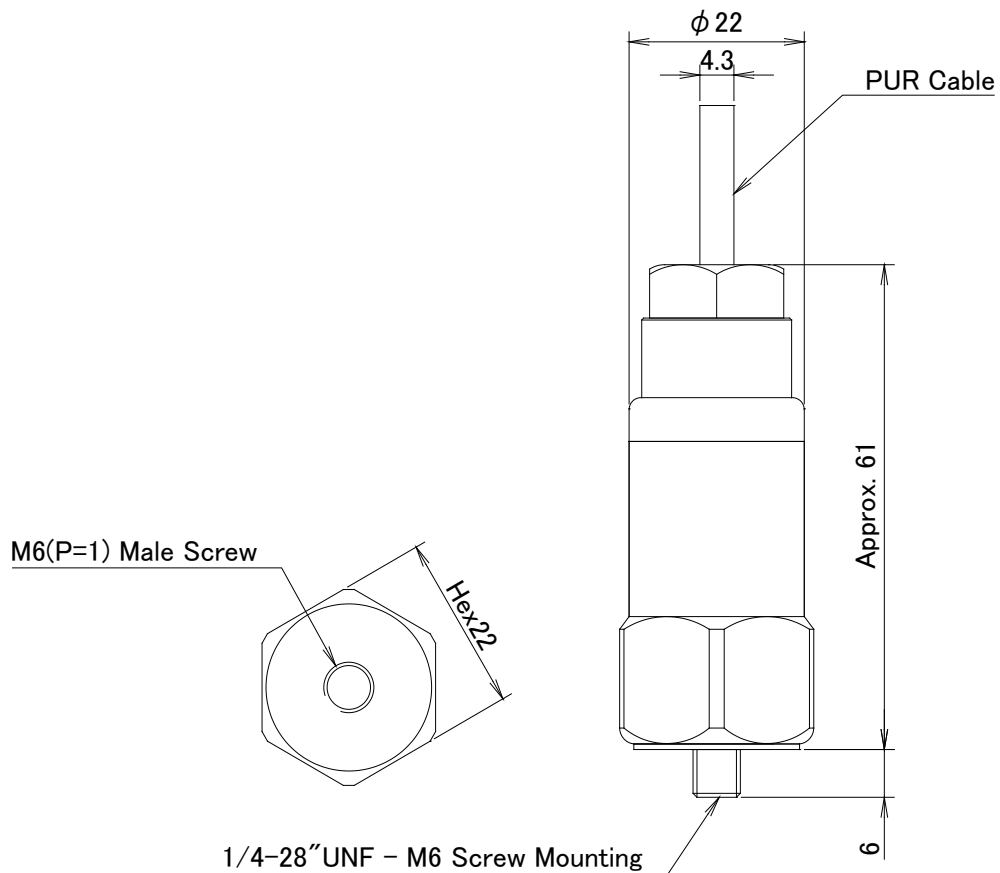

Outer Dimensions of the VP-1001000106 (Unit: mm)

(3) VP-1001005406 (Connector Type)

Detecting Method	Compression Type
Resonance Frequency	22kHz or more
Frequency Range	2Hz to 10kHz ± 1 dB
Voltage Sensitivity	10.2mV/(m/s ²) $\pm 10\%$
Max Measurement Acceleration	784m/s ²
Drive Current	0.5 to 8mA (18 to 30VDC)
Operating Temperature	-55 to +140°C
Protection Class	IP67
Weight	Approx. 125g (without Cable)
Case Material	SUS303
Mounting Method	M6 Screw
Cable Connecting Method	M12 Connector
Outer Dimensions	See below Figure

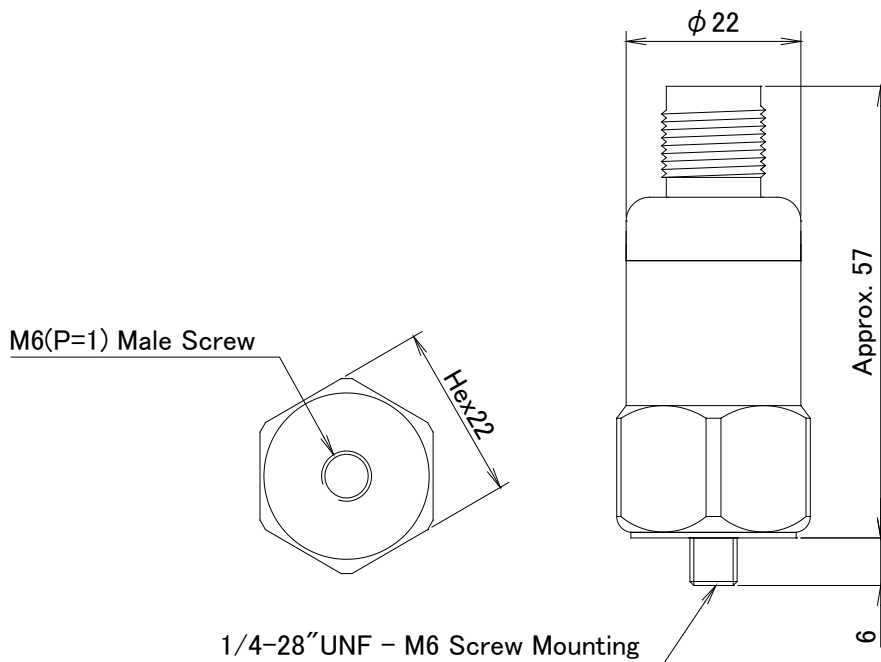

Outer Dimensions of the VP-1001005406 (Unit: mm)

Outside view of the Cable of VP-1001005406 (Connector Type)

Cable Sheath Material: PUR
Finished Outer Diameter: Approx. 5.9mm
Cable Length: 5m

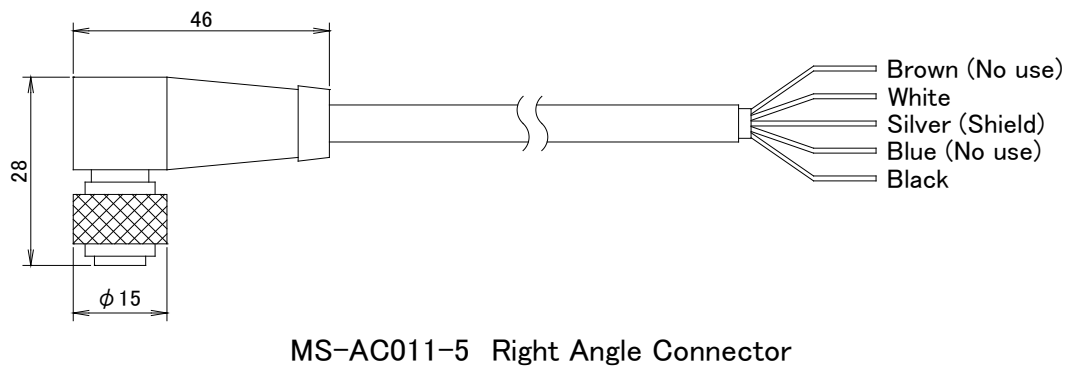
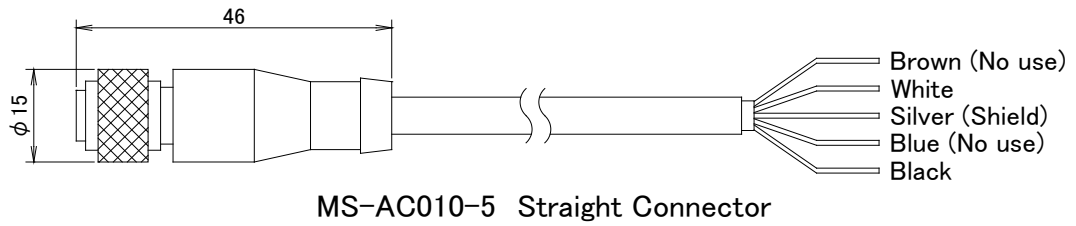

(4) VP-8021A (including Cable with a Connector)

Detecting Method	Capacitance (MEMS) Type
Resonance Frequency	17kHz or more
Frequency Range	10Hz to 8kHz $\pm 3\text{dB}$
Voltage Sensitivity	3.9mV/(m/s ²) $\pm 5\%$
Max Measurement Acceleration	490m/s ²
Drive Current	3.5mA (Typ.) 24VDC (Max.)
Operating Temperature	-30 to +120°C
Weight	Approx. 15g
Case Material	A5052 (Alumite treatment)
Mounting Method	M6 Screw
Cable Sheath Material	PVC or ETFE
Cable Length	5m (Standard Length)
Outer Dimensions	See below Figure

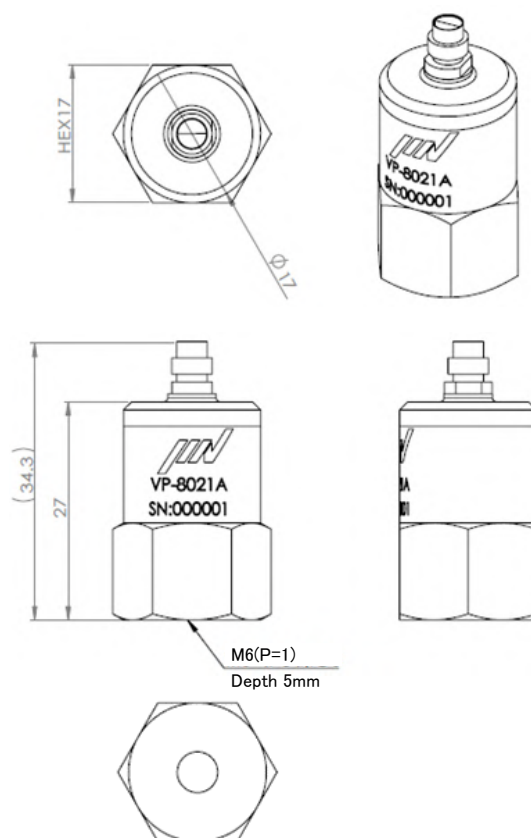

Outer Dimensions of the VP-8021A (Unit: mm)

Memo

For detailed specifications of the VP-8021A, please refer to the instruction manual for the VP-8021A.

12. Maintenance and Troubleshooting

12.1 Maintenance

Check the following items when performing maintenance and inspection.

- (1) Maintenance of the Converter
 - (a) Is the screw at the connector terminal where cable is connected loose?
 - (b) Is the connected cable damaged?
 - (c) Is the power supply as specified (whether POWER lamp is on)?
 - (d) Is there any abnormal heat generation while the power is on?
- (2) Maintenance of the Accelerometer
 - (a) Is accelerometer installed loosely (is it securely installed)?
 - (b) Is accelerometer or the cable of accelerometer damaged?
 - (c) Is there a problem with the grounding of measurement target device to which sensor is attached?

12.2 Troubleshooting

If you feel any malfunction or abnormality, please check the following before requesting repair or replacement. If the problem persists even after checking the following, please contact the purchasing agent or us.

Status	Cause	Treatment
POWER lamp does not light.	Power is not being supplied.	Please supply power.
	Cable connection is not made, or cable connection is incorrect.	Make sure to connect them securely.
	The supply power supply voltage is out of the specification range.	Check the power supply specifications.
	Accelerometer does not connect.	Please connect it.
	Accelerometer cable is disconnection.	Replace the cable of it.
Output of 4-20mADC does not change from 2mA.	Accelerometer cable is unconnected or disconnected.	Connect the cable correctly.
Vibration measurements are very small (large).	Accelerometer is installed in the wrong detection direction.	Reinstall in the correct detecting direction.
	Vibration is small (large).	—
①Vibration measurements are very unstable. ②Suddenly, vibration measurement became extremely large (small).	Accelerometer is not securely fixed.	Please fix it securely.
	There is a poor contact in cable connection part of the converter.	Please connect it securely.
	Accelerometer is broken.	If you own an accelerometer of the same specifications, check if the phenomenon is reproduced or if the phenomenon is switched by replacing the accelerometer.
	The converter is out of order.	If you own a converter of the same specifications, check if the phenomenon is reproduced or if the phenomenon is switched by replacing the converter.
	Vibration is unstable or large (small).	—

Appendix

Appendix 1 In case of the accelerometer is not grounded

Normally, the mounting place where the accelerometer is installed (the device to be measured) must be grounded.

If for some reason it cannot be grounded, ground it via the converter as shown in Fig.A-1.

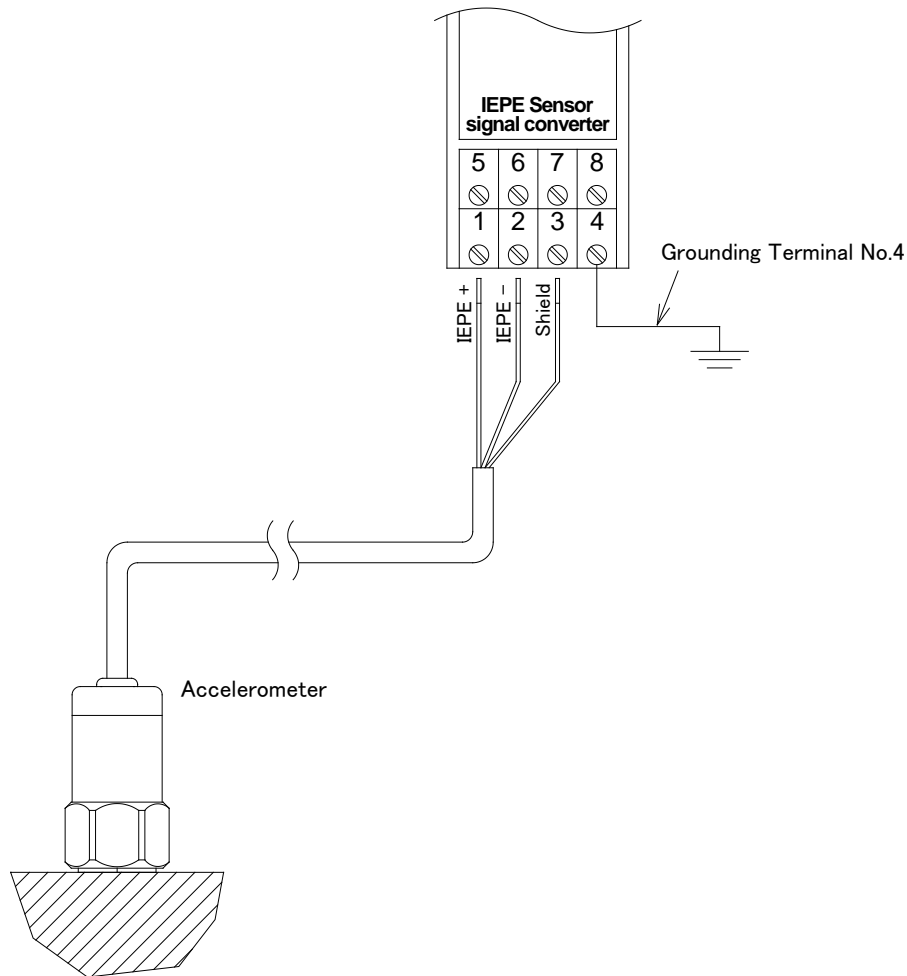

Fig.A-1 Wiring when the Accelerometer is not grounded

Memo

If the mounting place where the accelerometer is installed (device to be measured) is grounded, do not make the above wiring.

By grounding at two points, a loop is formed through the ground wire, which adversely affects the minute signal flowing through the accelerometer signal line, which may prevent correct vibration measurement.

Appendix 2 About voltage input connection specifications

The current for driving IEPE sensor (accelerometer) is output from accelerometer input terminal of the converter. It can be set to ON (IEPE sensor connection) or OFF (voltage input connection) of the drive current supply with jumper JP3 (see Fig.A-2).

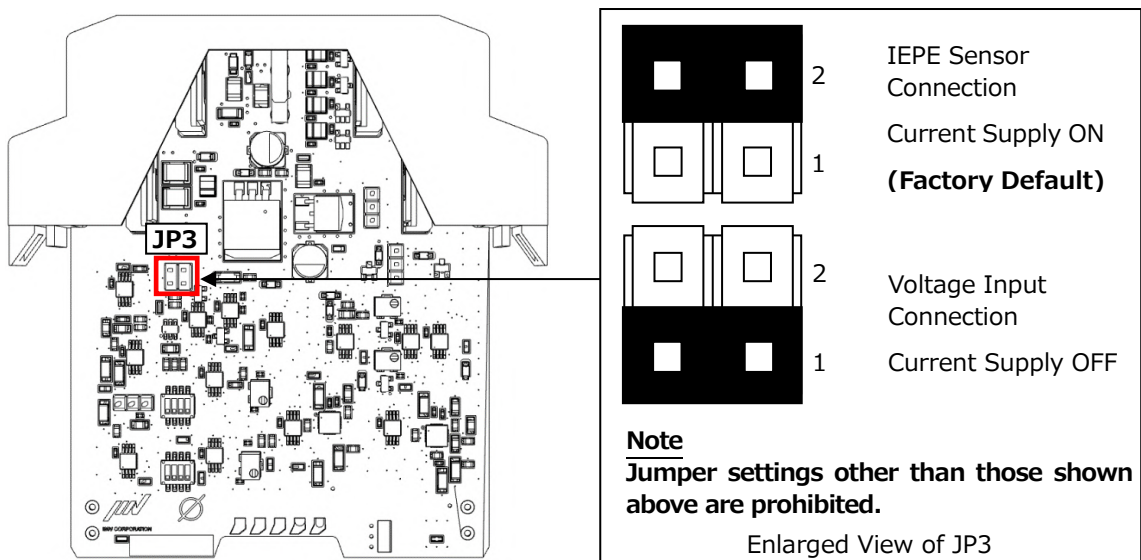

Fig.A-2 Drive Current Supply Setting

Memo

- (1) Refer to "Section 7" for how to pull out the board.
- (2) In the case of voltage input connection, POWER lamp lights up after power is supplied regardless of the cable connection status to the accelerometer input terminal.

◎ Example of using voltage input connection

Use accelerometer waveform output of another type of converter (VM-5011A etc.) and connect it to the accelerometer input terminal of voltage input specification the converter (VM-5011B).

This makes it possible to measure acceleration (m/s^2 rms) at the same time (see Fig.A-3).

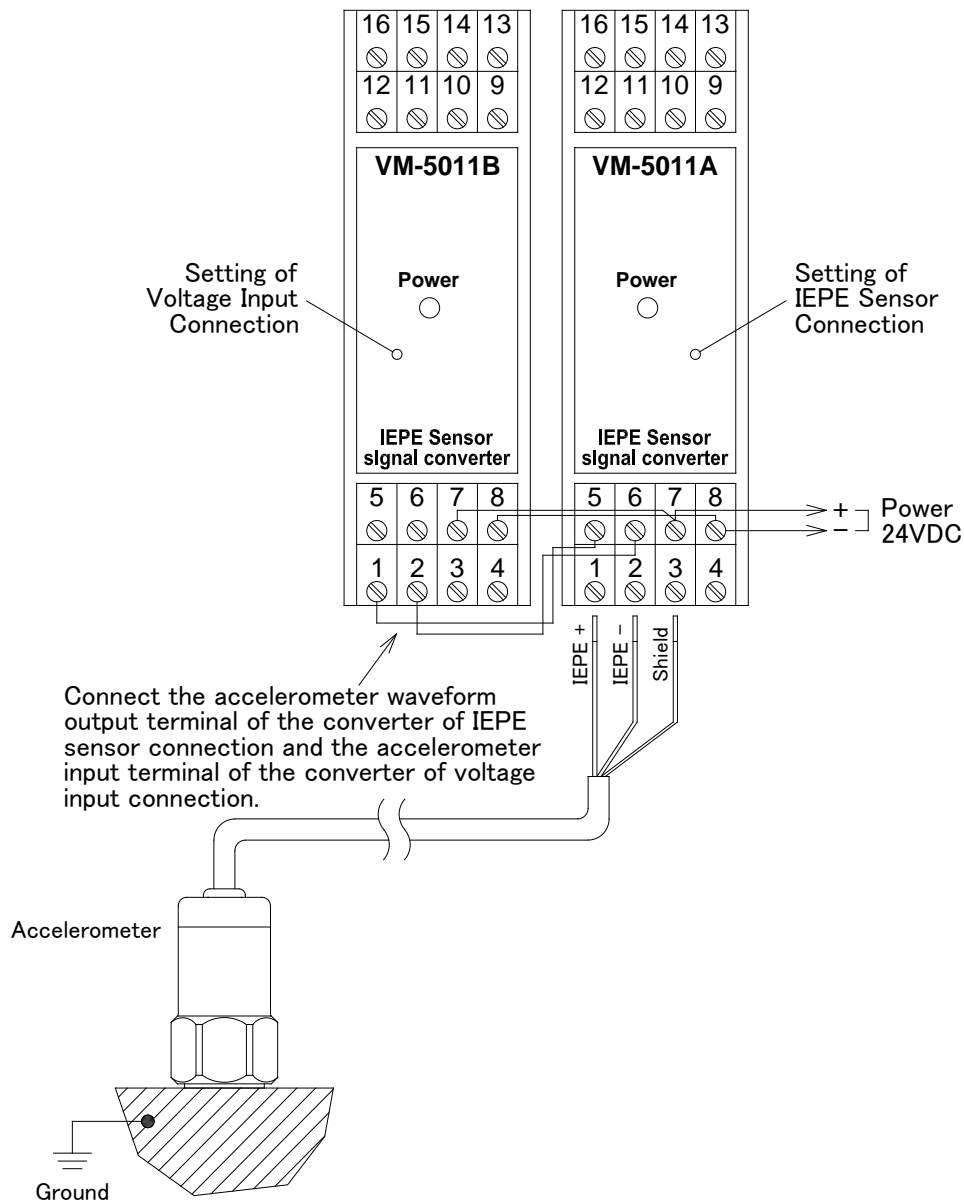

Fig.A-3 Connection example of voltage input specification the converter

⚠ Caution

Before performing the wiring work, turn off the power supply to the converter.

Appendix 3 About the Magnet for mounting the Accelerometer

The magnets for attaching the VP-100 series and the VP-8021A to measurement point are available as the options (see Table.A-1).

Table.A-1 The Magnets for mounting the Accelerometer

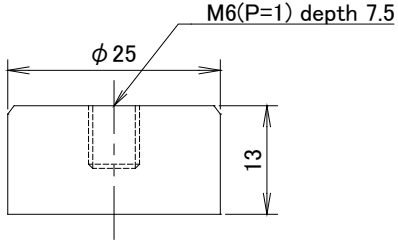
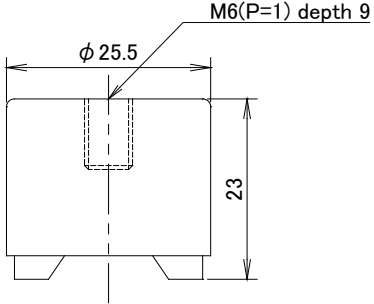
Model	MH-205R	MH-206R
Insulation	Non-insulation	Non-insulation
Material	Steel	Stainless
Adsorption Power	Approx. 160N	Approx. 150N
Use	for mounting Flat Surface	for mounting Curve Surface
Outer Dimensions Unit [mm]		

Caution

The adsorption force of magnet is very strong, even if it is installed to the accelerometer mounting surface from a very short distance, a large impact will be applied to it.

Accelerometer may break down due to a large impact, so once you touch the end of magnet to the mounting point, keep your hands on it and install it quietly.

Note

The adsorption force of magnet decreases due to deterioration over time. The Accelerometer may detect a large impact or vibration that occurs when it falls off the mounting surface due to a decrease in adsorption force.

VM-5011 Series Lineup

Model	Features	Measuring Mode (*1)			DC OUT Response Speed
		ACC RMS	E ACC RMS	VEL RMS	
VM-5011A	Simultaneously measures envelope acceleration, suitable for condition monitoring of bearings, and velocity according to ISO 2954:2012 filters.		●	●	$\tau=1s$ (63%)
VM-5011B	Simultaneously measures acceleration, and velocity according to ISO 2954:2012 filters. Faster response time of DC output enables more real-time vibration level output.	●		●	$\tau=0.3s$ (63%)

*1 The meaning of each phrase is as follows:

ACC: Acceleration, **E ACC**: Envelope Acceleration, **VEL**: Velocity

RMS: Root Mean Square

Revision History		
November 2024	Ver1.00	New Issued.
Contact Information for Inquiries		
IMV CORPORATION		
MES Business Division (Vibration Measuring Systems Sales Section)		
Address: 2-6-10 Takejima, Nishiyodogawa-ku, Osaka, 555-0011, Japan		
TEL: +81 50 1745 6779 FAX: +81 6 6471 3158		

*** Specifications and appearance described in this document are subject to change without notice.**