

IMV VIBRATION TEST SYSTEMS

J series

IMV-Smart™

ECO-Shaker

Air-cooled Vibration Test Systems

J260/EM7HAG



Long duration shock tests require high velocity and large displacement. J-series is a high-frequency system that offers usability and durability furnished with functions that accommodates high velocity and displacement testing.

[Expanded maximum test range]

Maximum velocity of Sine force: 94 in/s, Maximum velocity of Shock force 137 in/s, Maximum displacement: 4.0 in-p

[Patented upper (armature) support system PS Guide] Parallel Slope Guide is standard.

[All models can be directly coupled to a climatic chamber.]



1. High velocity and large displacement

High velocity of 94 in/s and Large displacement of 4.0 in-p.

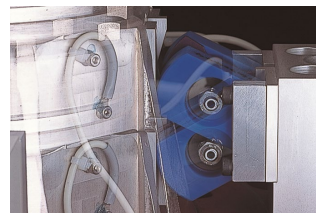

PS guide system

2. Improvement of testing environment

With the operation of Intelligence Shaker Management (ISM), EM range can reduce power consumption and CO2 emissions automatically.

3. User first principle

Compatible with K2 vibration controller. Intuitive interface leads The operator with user-friendly guidance.



eco-shaker

IMV CORPORATION

Air-Cooled Vibration Test Systems J260/EM7HAG



System Specification		
Frequency Range (Hz)	0-2,600 ^{*4}	
Rated Force	Sine (lbf)	12,150
	Random (lbf rms) ^{*1}	12,150
	Shock (lbf)	24,200
	High Velocity Shock (lbf) ^{*5}	21,595
Maximum Acc.	Sine (g)	87
	Random (g rms)	61
	Shock (g peak)	174
	High Velocity Shock (g peak) ^{*5}	155
Maximum Vel.	Sine (in/s)	94
	Shock (in/s peak)	94
	High Velocity Shock (in/s peak) ^{*5}	137
Maximum Disp.	Sine (in-p)	4.0
	High Velocity Shock (in-p) ^{*5}	4.0
Maximum Travel (in-p)	4.6	
Maximum Load (lbs)	2,200	
Power Requirements (kVA) ^{*2}	86	
Breaker Capacity (A) ^{*3}	125	

Vibration Generator (J260)	
Armature Mass (lbs)	139
Armature Diameter (φ in)	17.6
Armature Resonance (Hz)	1,800
Allowance Eccentric Moment (lbf·in)	13,730
Mass (lbs)	9,040

Power Amplifier (2□GH7-J260)	
Maximum Output (kVA)	70
Amplifier Bay	2
Mass (lbs)	3,090

Cooling Blower (VAPE 710/N2)	
Mass (lbs)	816

Environmental Data		
Input Voltage Supply (3 φ, V)	220/480	
Compressed Air Supply (psi)	102	
Working Ambient Temperature	Shaker (°F)	32-104
	Amplifier (°F)	32-104

^{*1} Random force ratings are specified in accordance with ISO5344 conditions. Please contact IMV or your local distributor with specific test requirements.
^{*2} Power supply: 3-phase 220/480 V, 60 Hz. A transformer is required for other supply voltages.
^{*3} Breaker capacity for 480 V.

^{*4} Above 2,000Hz, the force rolls-off f at a rate of -12 dB/oct.

^{*5} For high-velocity option

^{*}The alphabet of A, B, or C can be entered in □. A: Voltage AC200V system (200 to 230), B: Voltage AC400V system (380A to 440V), C: 480V system (480V to 520V)

^{*}For random vibration tests, please set the test definition of the peak value of acceleration waveform to operate at less than the maximum acceleration of shock.

^{*}Frequency range values vary according to the sensor and vibration controller.

^{*}Armature mass and acceleration may change when a chamber is added.

Vibration Generator (J260)

a: W 60 in
b: H 52 in
c: D 44 in
d: 36 φin

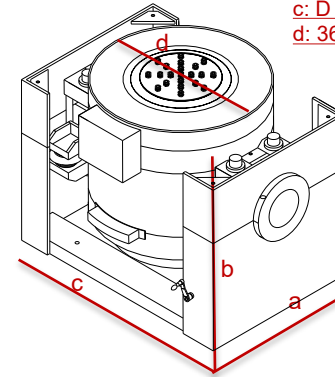
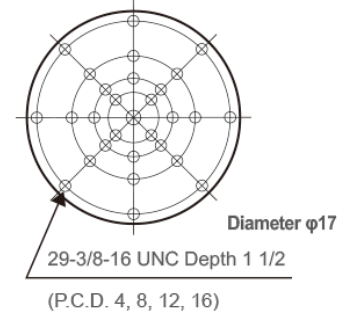
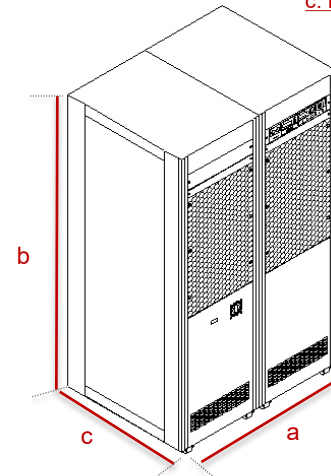

Table Insert Pattern (unit: inch)



Amplifier (2□GH7-J260)

a: W 46 in
b: H 77 in
c: D 34 in



Blower (VAPE 710/N2)

a: W 53 in
b: H 95 in
c: D 44 in

