

# IMV VIBRATION TEST SYSTEMS K series

## Water-cooled Vibration Test Systems **K200/EM50HAG**



K-series vibration test system is ideal for testing of large sized specimen with high acceleration test requirements, in the field of electronic assemblies, automotive parts, aviation, avionics parts satellite. K series is designed to meet international test standards including IEC, ISO and JIS.

IMV's patented upper (armature) support system; Parallel Slope Guide has improved the durability of the system extending the lifetime of the upper guidance system, with a lifetime of up to several times greater than the other standard shaker. Extended displacement available up to 100 mm (4 inch) with K series.



### 1. High-excitation-force and long stroke

Force rating up to 200 kN, wide frequency range up to 3,000. To allow long stroke testing, maximum displacement 100 mm (4 inch) is available with K125LS shaker.

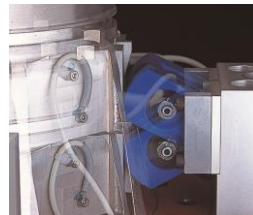

PSG guide system

### 2. Easy maintenance

All connections of electricity and water are in the upper part of the armature. It is easy to inspect and change the armature



### 3. Improvement of testing environment

No exhaust noise of the cooling blower. Further, with the operation of intelligence Shaker Management (ISM), EM range can reduce power consumption and CO2 emissions automatically.

eco-shaker

IMV CORPORATION





System Specification		
System Model	K200/EM50HAG	
Frequency Range (Hz)	0-2,000	
Rated Force	Sine (kN)	200
	Random (kN rms) <sup>*1</sup>	200
	Shock (kN)	800
	High Velocity Shock (kN)	520
Maximum Acc.	Sine (m/s <sup>2</sup> )	1,000
	Random (m/s <sup>2</sup> rms)	700
	Shock (m/s <sup>2</sup> )	2,000
	High Velocity Shock (m/s <sup>2</sup> )	2,000
Maximum Vel.	Sine (m/s)	2.0
	Shock (m/s peak) <sup>*3</sup>	2.4
	High Velocity Shock (m/s peak)	3.5
Maximum Disp.	Sine (mmp-p)	76.2
	Maximum Travel (mmp-p)	86
Maximum Load (kg)	2,000	
Power Requirements (kVA) <sup>*2</sup>	300	
Breaker Capacity (A)	-	

Vibration Generator (K200)	
Armature Mass (kg)	200
Armature Diameter (φ mm)	650
Armature Resonance (Hz)	1,600
Allowance Eccentric Moment (Nm)	4,900
Mass (kg)	19,000

Power Amplifier	
	EM50HAG-K200
Maximum Output (kVA)	300
Mass (kg)	6,000

Cooling (VE-HE-150-SA)		
Mass (kg)	600	
Environmental Data		
Input Voltage Supply (3 φ, V)	380/400/415/440	
Compressed Air Supply (Mpa)	0.7	
Facility Cooling Water Flow Rate (l/min)	650 at Δt=5°C	
	229 at Δt=12°C	
Working Ambient Temperature	Temperature (°C)	0-40
	Amplifier (°C)	0-85

Vibration Generator (K200)

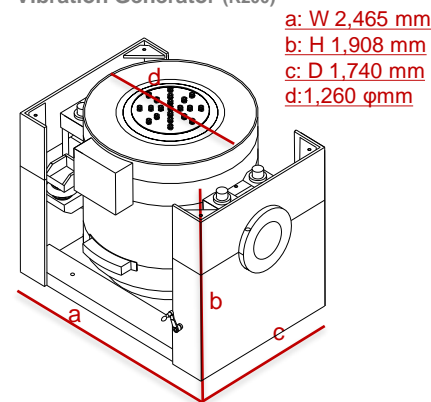
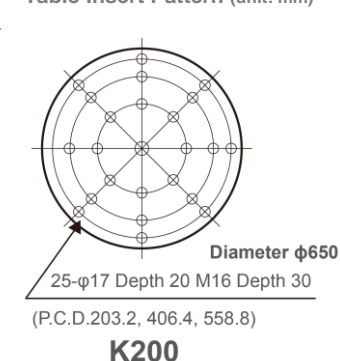
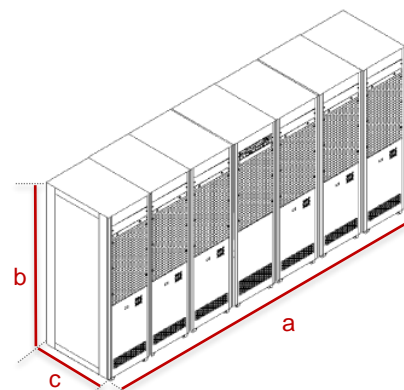

Table Insert Pattern (unit: mm)



Amplifier (EM50HAG-K200)

a: W 4,060 mm  
b: H 1,950 mm  
c: D 850 mm



Heat Exchanger

a: W 1,050 mm  
b: H 1,900 mm  
c: D 800 mm

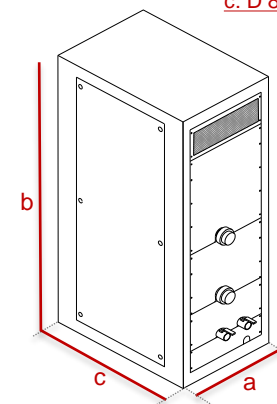

<sup>\*1</sup> Random force ratings are specified in accordance with ISO5344 conditions.  
<sup>\*2</sup> Power supply: 3-phase 380/400/415/440 V, 50/60 Hz. A transformer is required for other supply voltages.  
<sup>\*3</sup> If the tests (Sweep or Spot) include high velocity, the maximum velocity value should be reduced to 1.4 m/s.  
<sup>\*</sup>The specification shows the maximum system performance. For long-duration tests, system must be de-rated up to 70%.  
<sup>\*</sup>Continuous use at maximum levels may cause failure. Please contact IMV if your system operates at more than 70%.  
<sup>\*</sup>For random vibration tests, please set the test definition of the peak value of acceleration waveform to operate at less than the maximum acceleration of shock.  
<sup>\*</sup>Frequency range values vary according to the sensor and vibration controller.  
<sup>\*</sup>Armature mass and acceleration may change when a chamber is added.